

The **MX210R** is Maxam's regional all-position tire, engineered with the patented EcoPoint³ compound technology, taking efficiency and performance to new heights with optimized mileage, fuel economy and wet traction. Featuring a solid shoulder for enhanced durability and retreadability, the **MX210R** delivers unparalleled durability and performance for regional applications.



FUEL ECONOMY



WET TRACTION



EXCELLENT RETREADABILITY



MX210R

EXPERIENCE THE

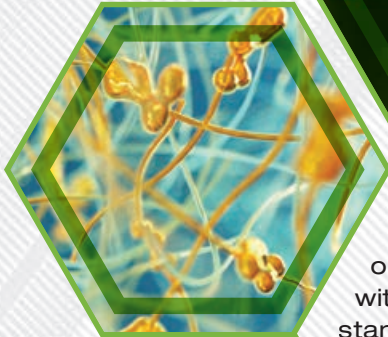

The MX210R is engineered with our proprietary EcoPoint³ compound technology. EcoPoint³ optimizes mileage, fuel economy and wet traction without compromising performance, setting a new standard for long-haul application.



UNMATCHED WET TRACTION FOR THE HIGHEST PERFORMANCE



MAXIMUM WEAR RESISTANCE FOR LONGEST TIRE LIFE



MINIMUM ROLLING RESISTANCE FOR OPTIMAL FUEL ECONOMY



SCAN TO LEARN MORE

OPTIMIZED CENTER LUGS

Provides excellent traction, improved wear resistance and evacuates water in wet conditions.

EcoPoint³ TECHNOLOGY COMPOUND

Patented EcoPoint³ compound technology enables maximum fuel efficiency and wet traction and conserves energy for enhanced rolling resistance.

SOLID SHOULDER

Improved stability, mileage, and wear resistance in high scrub applications.

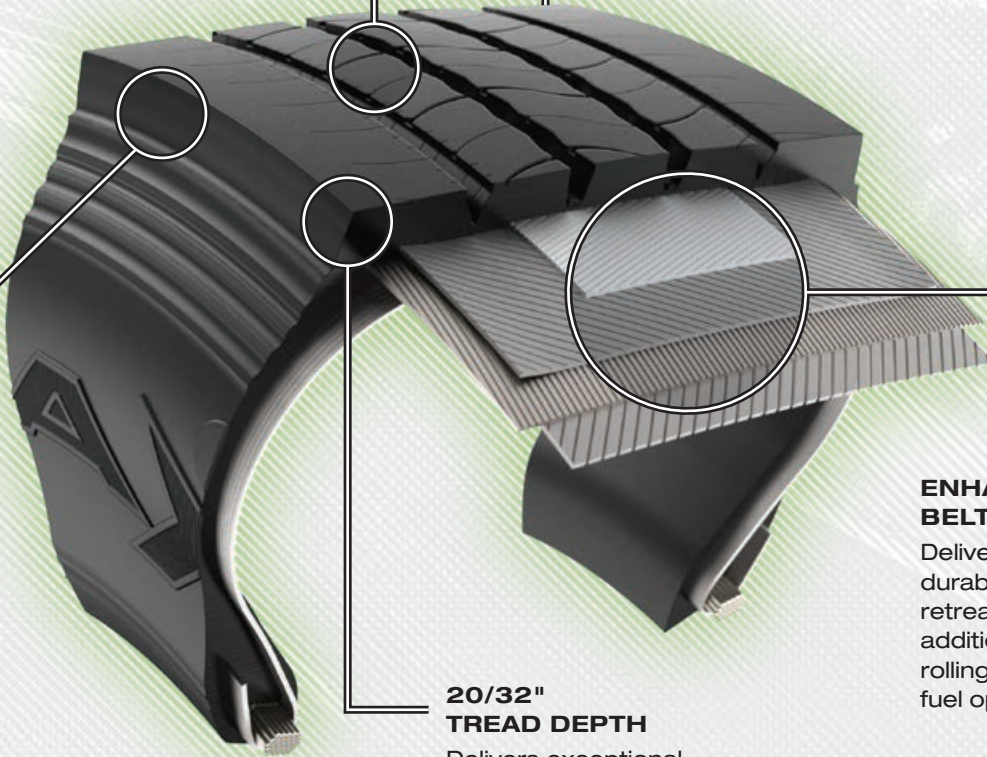
ENHANCED STEEL BELT PACKAGE

Delivers enhanced durability and retreadability in addition to minimum rolling resistance for fuel optimization.

20/32" TREAD DEPTH

Delivers exceptional mileage, promising unparalleled durability.

CODE	SIZE	LI	SR	PR	TD	RIM	OD	SW	SLR	LCC 1X	LCC 2X
V221008	11R22.5	144/142	M	14PR	20	8.25	41.9	11.0	19.3	6175@105	5840@105
V221000	11R22.5	146/143	M	16PR	20	8.25	41.9	11.0	19.3	6610@120	6005@120
V221009	11R24.5	146/143	M	14PR	20	8.25	43.5	11.0	20.3	6610@105	6005@105
V221001	11R24.5	149/146	M	16PR	20	8.25	43.5	11.0	20.3	7160@120	6610@120